

(12) UK Patent Application (19) GB (11) 2 113 920 A

- (21) Application No 8302013
(22) Date of filing 25 Jan 1983
(30) Priority data
(31) 57/009048
(32) 26 Jan 1982
(33) Japan (JP)
(43) Application published
10 Aug 1983
(51) INT CL³
H01H 13/12 13/70
(52) Domestic classification
H1N 593 618 637 646
854 664 700 70X 717
805 HG HH
(56) Documents cited
GB 1252724
GB 1168441
GB 1124333
GB 0869293
(58) Field of search
H1N
(71) Applicant
Alps Electric Co. Ltd.,
(Japan),
1-7 Yukigaya,
Otsuka-cho,
Ota-ku,
Tokyo 145,
Japan
(72) Inventors
Taneo Murata,
Shinji Iwasaki
(74) Agent and/or address for
service
Michael A. Enskat,
5 Richards Close,
Hillingdon,
Middlesex,
UB10 0BT

(54) Push-button electrical switch

(57) A push-button switch has a rubber domed shaped member 13 having an annular base 13a which engages an annular channel 11a in an insulating base board 11.

Projections 11d upstanding from the base board 11 are bent over to hold the dome shaped member 13 captive on the base board 11. A pair of spaced contacts 12 are mounted on

the base board 11 within the area encircled by the channel 11a. An electrically conductive rubber contact 14 on the inner surface of the dome shaped member 13 is arranged to bridge the two contacts 12 when the dome is depressed.

By providing the base board 11 with the means to hold the dome shaped member captive, the number of separate parts required for the assembly of the switch is reduced.

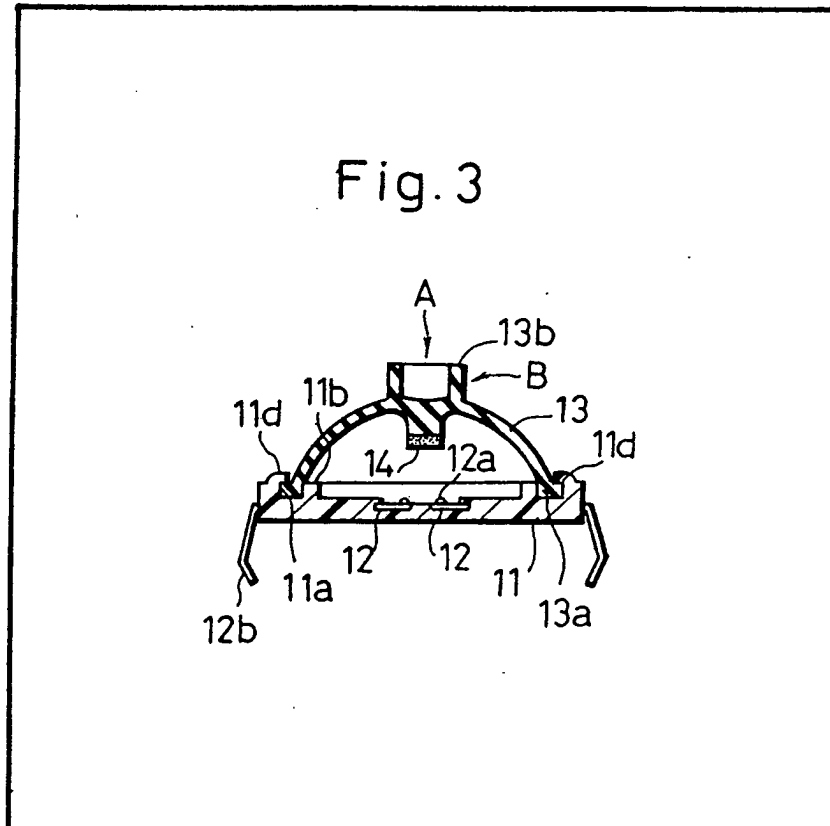

GB 2 113 920 A

Fig.1
PRIOR ART

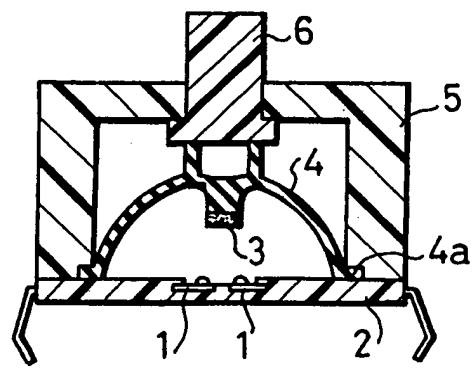

Fig. 2

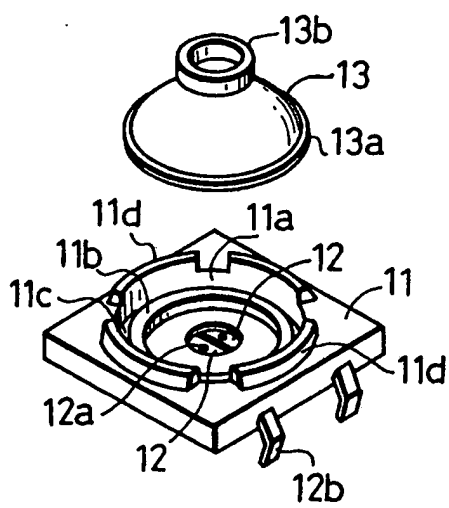
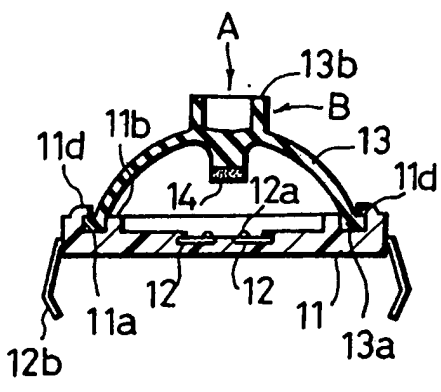

Fig. 3



SPECIFICATION

Push-button switch

The present invention relates to push-button switches.

5 According to the present invention, there is provided a push-button switch comprising a cup-shaped rubber cover having a rubber electrical contact on an inner face thereof, and an electrically insulating board, the board having
10 fixed electrical contacts in a central portion thereof, outer and inner circular walls encircling said fixed contacts to define an annular recess for receiving the annular rim of said rubber cover, and a plurality of projections formed around said
15 annular recess and bent inwardly to hold the rim of the rubber cover captive on the board.

According to the present invention, there is further provided a push-button switch comprising an electrically insulating base, first electrical
20 contact means on said base, an annular channel on said base encircling said first contact means, a dome-shaped member of electrically insulating resilient material having an annular extremity
25 engaging said annular channel, projection means on said base holding the annular extremity of the dome-shaped member captive in said annular channel, and second contact means on the inner surface of the dome-shaped member to co-
30 operate with the first contact means when the dome-shaped member is deformed against the bias of its own resilience.

A push-button switch embodying the invention will now be described with reference to the accompanying diagrammatic drawing in which:

35 Figure 1 is a section of the previously proposed push-button switch;

Figure 2 is a perspective exploded view of the push-button switch; and

40 Figure 3 is a section through the push-button switch of Figure 2.

In the previously proposed push-button switch shown in Figure 1, a cup-shaped rubber cover 4 is provided with a conductive rubber contact 3 on an inner surface thereof. The cover 4 is mounted
45 on an insulating board 2 provided with a pair of fixed contacts 1, 1 buried therein. A cylindrical insulating case 5 is mounted on the insulating board 2 so as to enclose the rubber cover 4. The lower end portion 4a of the rubber cover 4 is held captive between the case 5 and insulating board 2, and a push-button 6 is movably fitted in the
50 case 5. When this push-button 6 is pressed, the rubber cover 4 is deformed to cause the rubber contact 3 to come into engagement with the two fixed contacts 1. When the push-button 6 is then released, the rubber cover 4 returns to its original position due to its own resilience and so the push-button 6 also returns to the state that it was in before it had been pressed.

60 In this push-button switch, the lower end portion 4a of the rubber cover 4 is held between the case 5 and insulating board 2, so that the rubber cover 4 is held firmly. However, this push-button switch requires a separate case 5 and

65 push-button 6. This causes the number of parts and manufacturing cost to increase, and renders an operation for assembling the push-button switch troublesome. Accordingly, the productivity of the push-button switch is low, and the
70 dimensions thereof increase.

The push-button shown in Figures 2 and 3 has an insulating board or base 11 carrying a pair of fixed contacts 12, 12. Contact portions 12a of the fixed contacts 12, 12 are exposed in the central
75 section of the insulating board 11, and terminal portions 12b project downward from a peripheral section thereof.

The insulating board 11 is also provided with an outer circular wall 11a, and an inner circular wall 11b, which is formed so as to be spaced from the outer wall 11a at a predetermined distance and surround the contact portions 12a. The inner circular wall 11b is slightly lower than the outer circular wall 11a, and an annular groove 11c is
85 formed therebetween. At least two projections 11d . . . are formed around the groove 11c substantially in concentric relation thereto.

A cup- or dome-shaped rubber cover 13 is provided with an electrically conductive rubber contact 14 in an inner portion thereof. The rubber cover 13 has an annular end portion 13a at its lower extremity, and a cup-shaped pressing portion 13b at an upper section thereof. The annular end portion 13a is fitted in the annular
90 groove 11c between the outer and inner circular walls 11a, 11b on the insulating board 11.

Each of the projections 11d . . . is bent inward by thermally deforming or pressing the same, to fix under pressure the projections 11d to an upper
100 surface of the end portion 13a of the rubber cover 13. Consequently, the rubber cover 13 is set with the end portion 13a in a firmly-held state.

When the pressing portion 13b of the rubber cover 13 in the push-button switch is pressed in the direction of the arrow A in Figure 3, the rubber cover 13 is deformed, so that the rubber contact 14 comes into engagement with the two fixed contacts 12, 12. Consequently, the contacts are closed. When the pressing portion 13b is released, the rubber cover 13 returns to the original position under its own resilience, so that the contacts are opened.

The pressing portion 13b of the rubber cover 13 is pressed in some cases in the direction (lateral direction) of an arrow B in Figure 3. At this time, the end portion 13a is drawn to the left in Figure 3 as the rubber cover 13 is deformed but the inner circular wall 11b prevents the end portion 13a from being displaced. Thus, the end portion 13a is kept held between the outer and inner circular walls 11a, 11b, so that the rubber cover 13 is not removed.

The end portion 13a of the cup-shaped rubber cover 13, which is provided with the conductive rubber contact 14 on an inner surface thereof, is fitted and locked in the annular recess 11c between the outer and inner circular walls 11a, 11b on the insulating board 11, and the projections 11d . . . are bent inwardly to thereby